

Genie®



Operator's Manual

with Maintenance Information

Original Instructions
Fourth Edition
First Printing
Part No. 133535

S™-100

S™-105

S™-120

S™-125

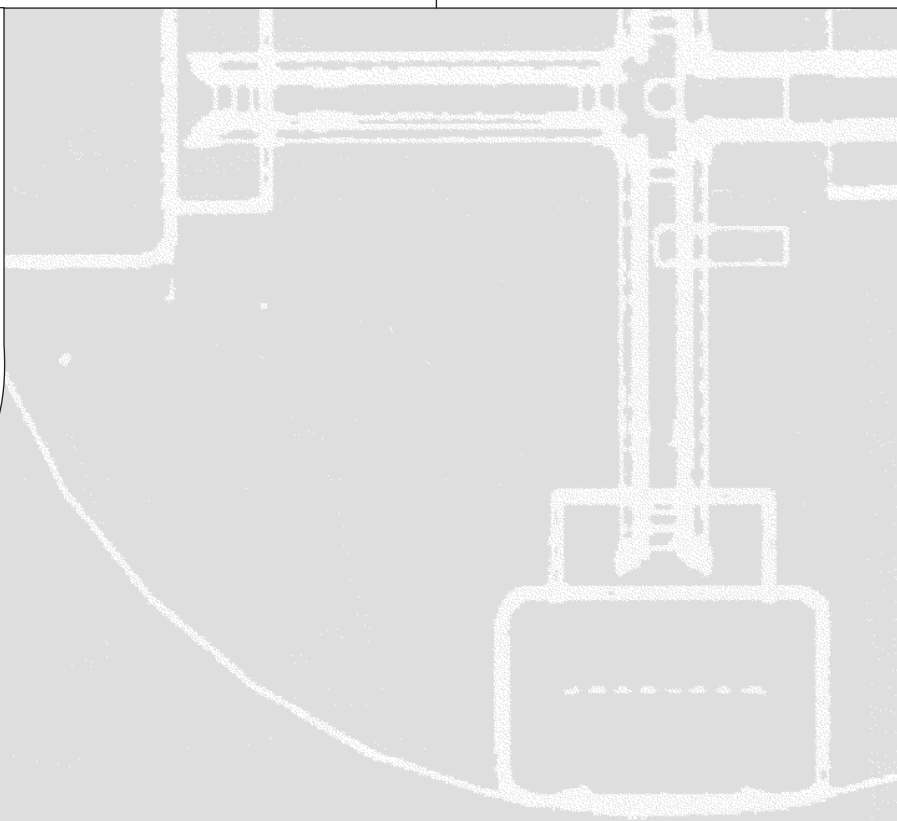

Important

Read, understand and obey these safety rules and operating instructions before operating this machine. Only trained and authorized personnel shall be permitted to operate this machine. This manual should be considered a permanent part of your machine and should remain with the machine at all times. If you have any questions, call Genie Industries.

Contents

	Page
Safety Rules	1
Legend	7
Controls	8
Pre-operation Inspection	11
Maintenance	13
Function Tests	16
Workplace Inspection	22
Operating Instructions	23
Transport and Lifting Instructions	29
Decals	32
Specifications	38

Contact us:

Internet: <http://www.genielift.com>

E-mail: techpub@genieind.com

Copyright © 2000 by Genie Industries

Fourth Edition: First Printing, November 2009

"Genie" is a registered trademark of Genie Industries in the U.S.A. and many other countries. "S" is a trademark of Genie Industries.

These machines comply with
ANSI/SIA 92.5

 Complies with EC Directive 2006/42/EC
See EC Declaration of Conformity

 Printed on recycled paper

Printed in U.S.A.

Safety Rules



Danger

Failure to obey the instructions and safety rules in this manual will result in death or serious injury.

Do Not Operate Unless:

- You learn and practice the principles of safe machine operation contained in this operator's manual.
 - 1 Avoid hazardous situations.**

Know and understand the above principle before going on to the next section.
 - 2 Always perform a pre-operation inspection.
 - 3 Always perform function tests prior to use.
 - 4 Inspect the workplace.
 - 5 Only use the machine as it was intended.
- You read, understand and obey the manufacturer's instructions and safety rules—safety and operator's manuals and machine decals.
- You read, understand and obey employer's safety rules and worksite regulations.
- You read, understand and obey all applicable governmental regulations.
- You are properly trained to safely operate the machine.

SAFETY RULES

Electrocution Hazards

This machine is not electrically insulated and will not provide protection from contact with or proximity to electrical current.

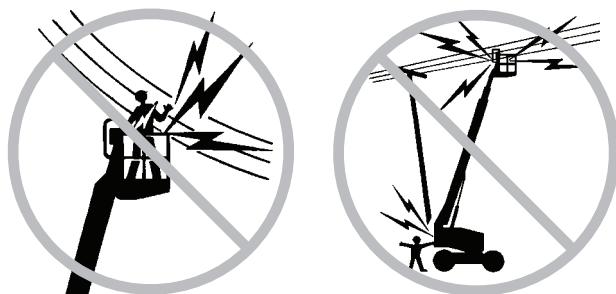

Maintain safe distances from electrical power lines and apparatus in accordance with applicable governmental regulations and the following chart.

Voltage Phase to Phase	Minimum Safe Approach Distance	
	Feet	Meters
0 to 300V	Avoid Contact	
300V to 50KV	10	3.05
50KV to 200KV	15	4.60
200KV to 350KV	20	6.10
350KV to 500KV	25	7.62
500KV to 750KV	35	10.67
750KV to 1000KV	45	13.72

Allow for platform movement, electrical line sway or sag and beware of strong or gusty winds.

Keep away from the machine if it contacts energized power lines. Personnel on the ground or in the platform must not touch or operate the machine until energized power lines are shut off.

Do not use the machine as a ground for welding unless the machine is equipped with the weld line to platform option and it is properly connected.

Tip-over Hazards

Occupants, equipment and materials shall not exceed the maximum platform capacity.

Maximum platform capacity

S-100	750 lbs	340 kg
S-105	500 lbs	227 kg
S-120	750 lbs	340 kg
S-125	500 lbs	227 kg

Maximum occupants

2

The weight of options and accessories, such as pipe cradles, panel cradles and welders, will reduce the rated platform capacity and must be factored into the total platform load. See the decals on the options.

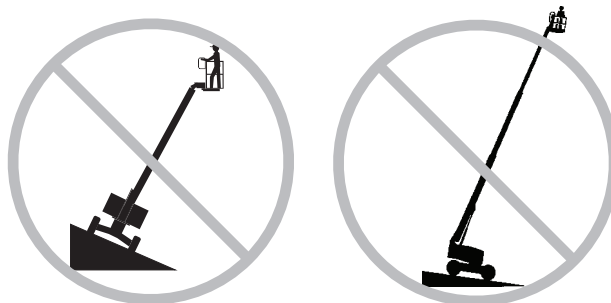

Do not raise or extend the boom unless the machine is on a firm, level surface.

Do not depend on the tilt alarm as a level indicator. The tilt alarm sounds in the platform only when the machine is on a severe slope.

SAFETY RULES

If the tilt alarm sounds:

Do not extend, rotate or raise the boom above horizontal. Move the machine to a firm, level surface before raising the platform. If the tilt alarm sounds when the platform is raised, use extreme caution to retract the boom and lower the platform. Do not rotate the boom while lowering. Move the machine to a firm, level surface before raising the platform.

Do not use the platform controls to free a platform that is caught, snagged or otherwise prevented from normal motion by an adjacent structure. All personnel must be removed from the platform before attempting to free the platform using the ground controls.

Do not raise the boom when wind speeds may exceed 28 mph / 12.5 m/s. If wind speeds exceed 28 mph / 12.5 m/s when the boom is raised, lower the boom and do not continue to operate the machine.

Do not operate the machine in strong or gusty winds. Do not increase the surface area of the platform or the load. Increasing the area exposed to the wind will decrease machine stability.



Use extreme care and slow speeds while driving the machine in stowed position across uneven terrain, debris, unstable or slippery surfaces and near holes and drop-offs.

Do not drive the machine on or near uneven terrain, unstable surfaces or other hazardous conditions with the boom raised or extended.

Do not drive the machine on a slope that exceeds the maximum uphill, downhill or side slope rating of the machine. Slope rating applies to machines in the stowed position

Maximum slope rating, stowed position

Platform downhill	40% (22°)
Platform uphill	40% (22°)
Side slope	25% (14°)

Note: Slope rating is subject to ground conditions and adequate traction.

Do not alter or disable the limit switches.

Do not push off or pull toward any object outside of the platform.

Maximum allowable side force - ANSI & CSA
150 lb / 667 N

Maximum allowable manual force - CE & Australia
90 lbs / 400 N

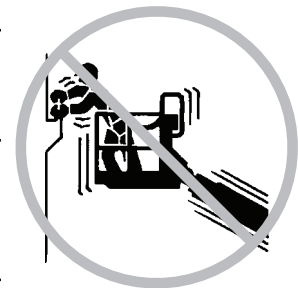

Do not alter or disable machine components that in any way affect safety and stability.

Do not replace items critical to machine stability with items of different weight or specification.

SAFETY RULES

Do not modify or alter an aerial work platform without prior written permission from the manufacturer. Mounting attachments for holding tools or other materials onto the platform, toeboards or guard rail system can increase the weight in the platform and the surface area of the platform or the load.

Do not place or attach overhanging loads to any part of this machine.

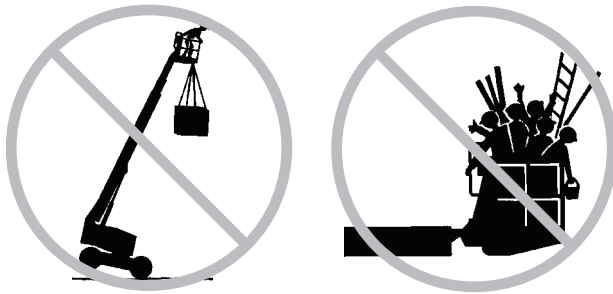

Do not place ladders or scaffolds in the platform or against any part of this machine.

Do not use the machine on a moving or mobile surface or vehicle.

Be sure all tires are in good condition and lug nuts are properly tightened.

Fall Hazards

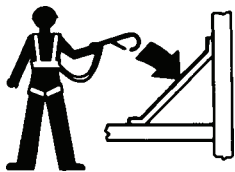

Occupants must wear a safety belt or harness in accordance with governmental regulations. Attach the lanyard to the anchorage point provided in the platform.

Do not sit, stand or climb on the platform guard rails. Maintain a firm footing on the platform floor at all times.

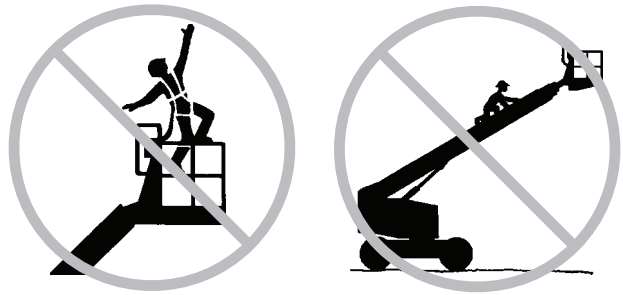

Do not climb down from the platform when raised.

Keep the platform floor clear of debris.

Lower the platform entry mid-rail or close the entry gate before operating.

Collision Hazards

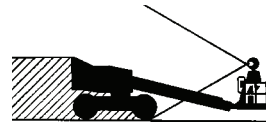

Be aware of limited sight distance and blind spots when driving or operating.

Be aware of the boom position and tailswing when rotating the turntable.

Check the work area for overhead obstructions or other possible hazards.



Be aware of crushing hazards when grasping the platform guard rail.

SAFETY RULES

Observe and use the circle and square markings and the color-coded direction arrows on the platform controls and drive chassis for drive and steer functions.

Operators must comply with employer, job site and governmental rules regarding the use of personal protective equipment.

No stunt driving or horseplay while operating a machine.

Do not operate a boom in the path of any crane unless the controls of the crane have been locked out and/or precautions have been taken to prevent any potential collision.

Do not lower the boom unless the area below is clear of personnel and obstructions.



Limit travel speed according to the condition of the ground surface, congestion, slope, location of personnel, and any other factors which may cause collision.

Component Damage Hazards

Do not use any battery or charger greater than 12V to jump-start the engine.

Do not use the machine as a ground for welding.

Explosion and Fire Hazards

Do not start the engine if you smell or detect liquid petroleum gas (LPG), gasoline, diesel fuel or other explosive substances.

Do not refuel the machine with the engine running.

Refuel the machine and charge the battery only in an open, well-ventilated area away from sparks, flames and lighted tobacco.

Do not operate the machine in hazardous locations or locations where potentially flammable or explosive gases or particles may be present.

Do not spray ether into engines equipped with glow plugs.

Damaged Machine Hazards

Do not use a damaged or malfunctioning machine.

Conduct a thorough pre-operation inspection of the machine and test all functions before each work shift. Immediately tag and remove from service a damaged or malfunctioning machine.

Be sure all maintenance has been performed as specified in this manual and the appropriate service manual.

Be sure all decals are in place and legible.

Be sure the operator's, safety and responsibilities manuals are complete, legible and in the storage container located on the platform.

SAFETY RULES

Bodily Injury Hazard

Do not operate the machine with a hydraulic oil or air leak. An air leak or hydraulic leak can penetrate and/or burn skin.

Always operate the machine in a well-ventilated area to avoid carbon monoxide poisoning.

Do not operate the machine unless the secondary extend cylinder cover is properly installed.

Improper contact with components under any cover will cause serious injury. Only trained maintenance personnel should access compartments. Access by the operator is only advised when performing a pre-operation inspection. All compartments must remain closed and secured during operation.

Weld Line to Platform Safety

Read, understand and obey all warnings and instructions provided with the welding power unit.

Do not connect weld leads or cables unless the welding power unit is turned off at the platform controls.

Do not operate unless the weld cables are properly connected.

Connect the positive lead to the twist-lock connector at the turntable and platform.

Clamp the negative lead to the ground post at the turntable and platform.

Decal Legend

Genie product decals use symbols, color coding and signal words to identify the following:



Safety alert symbol—used to alert personnel to potential personal injury hazards. Obey all safety messages that follow this symbol to avoid possible injury or death.



Red—used to indicate the presence of an imminently hazardous situation which, if not avoided, will result in death or serious injury.



Orange—used to indicate the presence of a potentially hazardous situation which, if not avoided, could result in death or serious injury.



Yellow with safety alert symbol—used to indicate the presence of a potentially hazardous situation which, if not avoided, may cause minor or moderate injury.



Yellow without safety alert symbol—used to indicate the presence of a potentially hazardous situation which, if not avoided, may result in property damage.



Green—used to indicate operation or maintenance information.

Legend

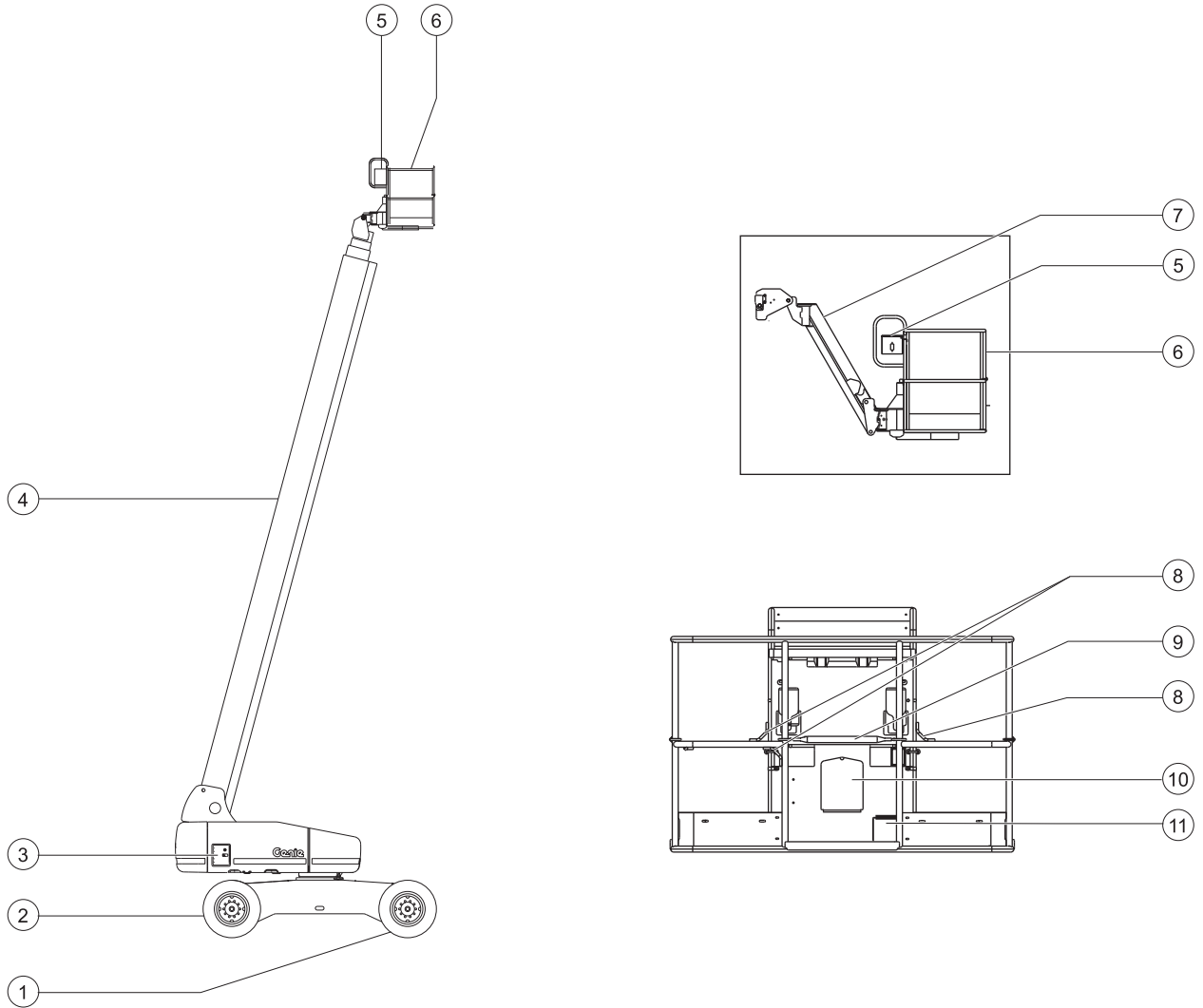

- 1 Circle-end tire (yellow arrow)
- 2 Square-end tire (blue arrow)
- 3 Ground controls
- 4 Boom
- 5 Platform controls
- 6 Platform
- 7 Jib boom (S-105 and S-125)

- 8 Lanyard anchorage point
- 9 Sliding mid-rail
- 10 Manual storage container
- 11 Foot switch

Controls

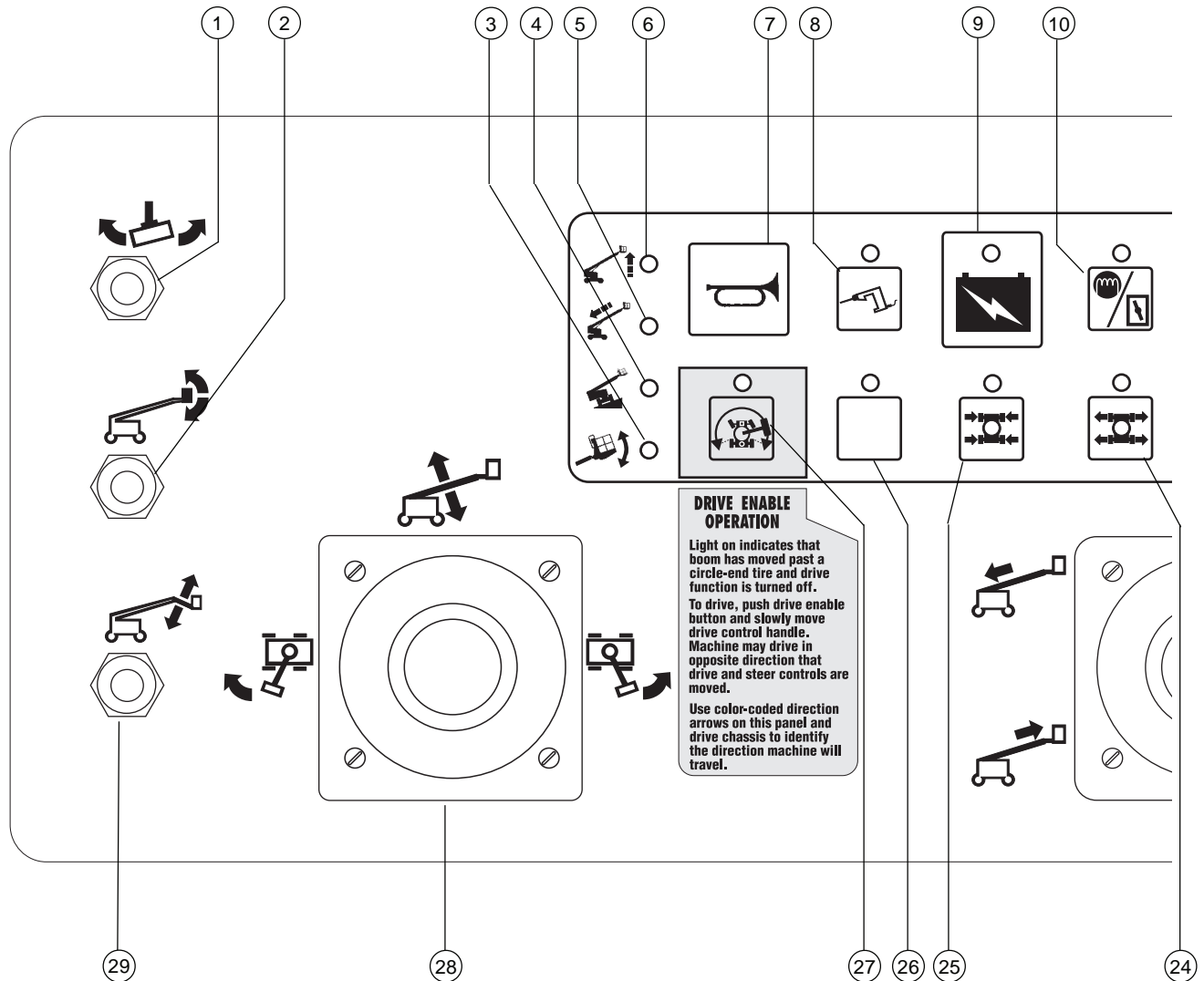

Platform Control Panel

- 1 Platform rotate switch
- 2 Platform level switch
- 3 Platform Not Level indicator light
- 4 Machine Not Level indicator light
- 5 Retract Boom indicator light
- 6 Raise Boom indicator light
- 7 Horn button
- 8 Generator button with indicator light (option)

- 9 Auxiliary power button with indicator light
- 10 Diesel models: Glow plug button with indicator light
Gasoline/LPG models: Choke button with indicator light
- 11 Engine start button with indicator light

- 12 Engine idle (rpm) select button with indicator lights:
 - Rabbit & Foot Switch: foot switch activated high idle
 - Turtle: low idle
 - Rabbit: high idle
- 13 Gasoline/LPG models: Gasoline/LPG select button with indicator lights
- 14 Fault indicator light
- 15 Low fuel indicator light
- 16 Check engine indicator light



CONTROLS

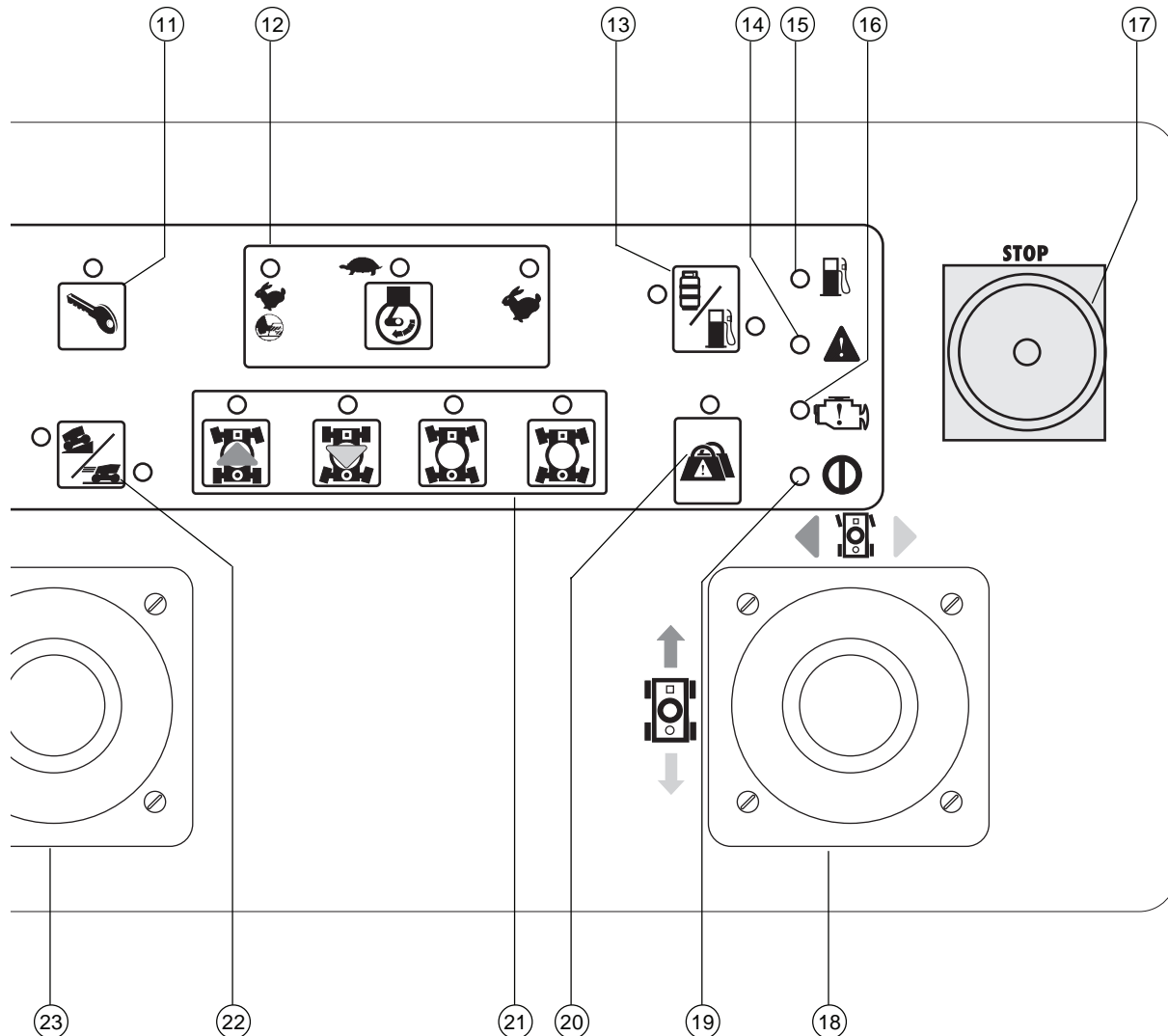

- 17 Red Emergency Stop button
- 18 Dual axis proportional control handle for drive and steer functions
OR Proportional control handle for drive function and thumb rocker for steer function
- 19 Power indicator light
- 20 Platform overload indicator light (if equipped)
- 21 Steer mode select buttons with indicator lights

- 22 Drive select button with indicator lights:
Machine on incline symbol: Low range operation for inclines
Machine on level surface symbol: High range operation for maximum drive speed
- 23 Single axis proportional control handle for boom extend/retract function
- 24 Extend axle button with indicator light

- 25 Retract axle button with indicator light
- 26 Used for optional equipment
- 27 Drive enable button with indicator light
- 28 Dual axis proportional control handle for boom up/down and turntable rotate left/right functions
- 29 S-105 and S-125 models: Jib boom up/down toggle switch



CONTROLS

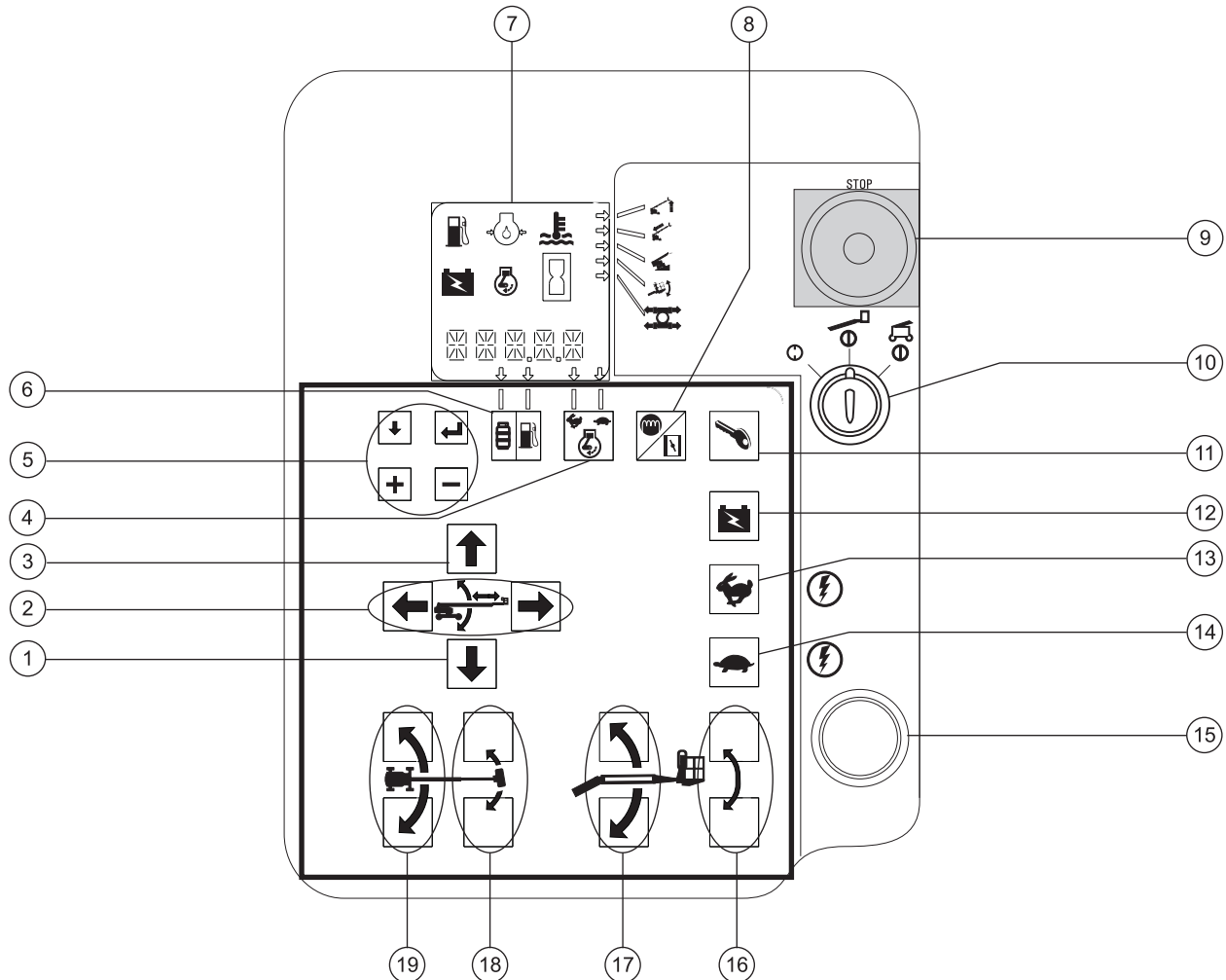

Ground Control Panel

- | | |
|--|---|
| 1 Boom down button | 11 Engine start button |
| 2 Boom extend/retract buttons | 12 Auxiliary power button |
| 3 Boom up button | 13 High speed function enable button |
| 4 Engine speed select button | 14 Low speed function enable button |
| 5 LCD screen control buttons | 15 Alarm |
| 6 Gasoline/LPG select button | 16 Platform level up/down buttons |
| 7 LCD readout screen | 17 S-105 and S-125 models: Jib boom up/down buttons |
| 8 Diesel models: Glow plug button
Gasoline/LPG models: Choke button | 18 Platform rotate left/right buttons |
| 9 Red Emergency Stop button | 19 Turntable rotate left/right buttons |
| 10 Key switch for off/platform/ground selection | |



Pre-operation Inspection



Do Not Operate Unless:

- You learn and practice the principles of safe machine operation contained in this operator's manual.

1 Avoid hazardous situations.

2 Always perform a pre-operation inspection.

Know and understand the above principles before going on to the next section.

3 Always perform function tests prior to use.

4 Inspect the workplace.

5 Only use the machine as it was intended.

Fundamentals

It is the responsibility of the operator to perform a pre-operation inspection and routine maintenance.

The pre-operation inspection is a visual inspection performed by the operator prior to each work shift. The inspection is designed to discover if anything is apparently wrong with a machine before the operator performs the function tests.

The pre-operation inspection also serves to determine if routine maintenance procedures are required. Only routine maintenance items specified in this manual may be performed by the operator.

Refer to the list on the next page and check each of the items.

If damage or any unauthorized variation from factory delivered condition is discovered, the machine must be tagged and removed from service.

Repairs to the machine may only be made by a qualified service technician, according to the manufacturer's specifications. After repairs are completed, the operator must perform a pre-operation inspection again before going on to the function tests.

Scheduled maintenance inspections shall be performed by qualified service technicians, according to the manufacturer's specifications and the requirements listed in the responsibilities manual.

PRE-OPERATION INSPECTION

Pre-operation Inspection

- Be sure that the operator's, safety and responsibilities manuals are complete, legible and in the storage container located in the platform.
- Be sure that all decals are legible and in place. See Decals section.
- Check for engine oil leaks and proper oil level. Add oil if needed. See Maintenance section.
- Check for hydraulic oil leaks and proper oil level. Add oil if needed. See Maintenance section.
- Check for engine coolant leaks and proper level of coolant. Add coolant if needed. See Maintenance section.
- Check for battery fluid leaks and proper fluid level. Add distilled water if needed. See Maintenance section.

Check the following components or areas for damage, improperly installed or missing parts and unauthorized modifications:

- Electrical components, wiring and electrical cables
- Hydraulic hoses, fittings, cylinders and manifolds
- Fuel and hydraulic tanks
- Drive and turntable motors and drive hubs
- Boom and axle wear pads
- Tires and wheels
- Engine and related components
- Limit switches and horn
- Alarms and beacons (if equipped)
- Nuts, bolts and other fasteners
- Platform entry mid-rail or gate

Check the entire machine for:

- Cracks in welds or structural components
- Dents or damage to machine
- Excessive rust, corrosion or oxidation
- Be sure that all structural and other critical components are present and all associated fasteners and pins are in place and properly tightened.

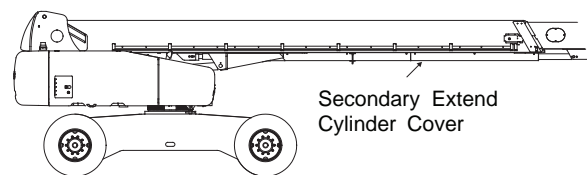

- Be sure the secondary extend cylinder cover is properly installed.
- After you complete your inspection, be sure that all compartment covers are in place and latched.

Maintenance



Observe and Obey:

- ☑ Only routine maintenance items specified in this manual shall be performed by the operator.
- ☑ Scheduled maintenance inspections shall be completed by qualified service technicians, according to the manufacturer's specifications and the requirements specified in the responsibilities manual.

Maintenance Symbols Legend

NOTICE

The following symbols have been used in this manual to help communicate the intent of the instructions. When one or more of the symbols appear at the beginning of a maintenance procedure, it conveys the meaning below.



Indicates that tools will be required to perform this procedure.



Indicates that new parts will be required to perform this procedure.



Indicates that a cold engine is required before performing this procedure.

Check the Engine Oil Level



Maintaining the proper engine oil level is essential to good engine performance and service life. Operating the machine with an improper oil level can damage engine components.

NOTICE

Check the oil level with the engine off.

- 1 Check the engine oil dipstick. Add oil as needed.

Cummins B3.3C80 Engine

Oil type	15W-40
----------	--------

Oil type - cold conditions	10W-30
----------------------------	--------

Deutz TD2011L04i Engine

Oil type	15W-40
----------	--------

Oil type - cold conditions	5W-30
----------------------------	-------

Perkins 804D-33T Engine

Oil type	15W-40
----------	--------

Oil type - cold conditions	5W-40
----------------------------	-------

MAINTENANCE

Check the Hydraulic Oil Level



Maintaining the hydraulic oil at the proper level is essential to machine operation. Improper hydraulic oil levels can damage hydraulic components. Daily checks allow the inspector to identify changes in oil level that might indicate the presence of hydraulic system problems.

- 1 Be sure that the boom is in the stowed position.
 - 2 Visually inspect the sight gauge located on the side of the hydraulic oil tank.
- ⦿ Result: The hydraulic oil level should be within the top 2 inches / 5 cm of the sight gauge.

Hydraulic oil specifications

Hydraulic oil type	Chevron Rykon Premium MV equivalent
--------------------	--

Check the Batteries



Proper battery condition is essential to good engine performance and operational safety. Improper fluid levels or damaged cables and connections can result in engine component damage and hazardous conditions.

⚠ WARNING Electrocutation hazard. Contact with hot or live circuits may result in death or serious injury. Remove all rings, watches and other jewelry.

⚠ WARNING Bodily injury hazard. Batteries contain acid. Avoid spilling or contacting battery acid. Neutralize battery acid spills with baking soda and water.

NOTICE The controls battery is behind the starter battery.

- 1 Put on protective clothing and eye wear.
- 2 Be sure that the battery cable connections are tight and free of corrosion.
- 3 Be sure that the battery hold-down bar is secure.
- 4 Remove the battery vent caps.
- 5 Check the battery acid level. If needed, replenish with distilled water to the bottom of the battery fill tube. Do not overfill.
- 6 Install the vent caps.

NOTICE Adding terminal protectors and a corrosion preventative sealant will help eliminate corrosion on the battery terminals and cables.

MAINTENANCE

Check the Engine Coolant Level - Liquid Cooled Models



Maintaining the engine coolant at the proper level is essential to engine service life. Improper coolant level will affect the engine's cooling capability and damage engine components. Daily checks will allow the inspector to identify changes in coolant level that might indicate cooling system problems.

- 1 Check the coolant fluid level. Add fluid as needed.
- ⦿ Result: The fluid level should be visible in the top tank of the radiator.

⚠ WARNING Burn Hazard. Do not remove the radiator cap if the engine and/or radiator is warm. The engine and radiator should be cool to the touch before performing the coolant level inspection.

Scheduled Maintenance

Maintenance performed quarterly, annually and every two years must be completed by a person trained and qualified to perform maintenance on this machine according to the procedures found in the service manual for this machine.

Machines that have been out of service for more than three months must receive the quarterly inspection before they are put back into service.

Function Tests



Do Not Operate Unless:

- ☑ You learn and practice the principles of safe machine operation contained in this operator's manual.

- 1 Avoid hazardous situations.
- 2 Always perform a pre-operation inspection.

3 Always perform function tests prior to use.

Know and understand the above principles before going on to the next section.

- 4 Inspect the workplace.
- 5 Only use the machine as it was intended.

Fundamentals

The function tests are designed to discover any malfunctions before the machine is put into service. The operator must follow the step-by-step instructions to test all machine functions.

A malfunctioning machine must never be used. If malfunctions are discovered, the machine must be tagged and removed from service. Repairs to the machine may only be made by a qualified service technician, according to the manufacturer's specifications.

After repairs are completed, the operator must perform a pre-operation inspection and function tests again before putting the machine into service.

- 1 Select a test area that is firm, level and free of obstruction.

At the Ground Controls

- 2 Turn the key switch to ground control.
- 3 Pull out the red Emergency Stop button to the on position.
- ☉ Result: The LCD screen will come on and display no error messages. The beacon (if equipped) should flash.

Note: In cold climates, the LCD readout screen will need to warm up before the display appears.

- 4 Start the engine (see Operating Instructions section).

Test Emergency Stop

- 5 Push in the red Emergency Stop button to the off position.
- ☉ Result: The engine should turn off and no functions should operate.
- 6 Pull out the red Emergency Stop button to the on position and restart the engine.

Test the Extendable Axles

Note: Start this test with the axles retracted.

- 7 At the ground controls, push and hold a function enable/speed select button and push the boom up button.
- ☉ Result: The boom should raise to 10° above horizontal and then stop. The boom should not raise above the limit switch unless both axles are extended.
- 8 Push and hold a function enable/speed select button and push the boom down button.
- ☉ Result: The boom should lower and return to the stowed position.

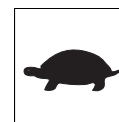

FUNCTION TESTS

9 Push and hold a function enable/speed select button and press the boom extend button.

⦿ Result: The boom should not extend.

10 Turn the key switch to platform control. At the platform controls, move the drive control handle in the forward direction and push the extend axle button.



⦿ Result: The machine should drive and the axles should extend. The indicator light will flash while the axles are moving and stay on when the axles are fully extended.

Note: The extend axle function will only work while the machine is moving.

11 Return to the ground controls. Turn the key switch to ground control. Push and hold a function enable/speed select button and push the boom up button and then the boom down button.

⦿ Result: The boom should raise and lower normally.

12 At the ground controls, push and hold a function enable/speed select button and push the boom extend button and the boom retract button.

⦿ Result: The boom should extend and retract normally.

Test the Machine Functions

13 Do not press and hold a function enable/speed select button. Attempt to activate each boom and platform function button.

⦿ Result: No boom and platform functions should operate.

14 Press and hold a function enable/speed select button and activate each boom and platform function button.

⦿ Result: All boom and platform functions should operate through a full cycle. The descent alarm (if equipped) should sound while the boom is lowering.

Test Auxiliary Controls

15 Turn the key switch to ground control and shut the engine off.

16 Pull out the red Emergency Stop button to the on position.

17 Simultaneously push and hold the auxiliary power button and push each boom function button or activate each boom function toggle switch.



Note: To conserve battery power, test each function through a partial cycle.

⦿ Result: All boom functions should operate.

FUNCTION TESTS

Test the Tilt Sensor

18 Push one of the LCD screen buttons until TURNTABLE LEVEL SENSOR X-DIRECTION appears.



- Result: The LCD screen should display the angle in degrees.

19 Push one of the LCD screen buttons until TURNTABLE LEVEL SENSOR Y-DIRECTION appears.

- Result: The LCD screen should display the angle in degrees.

20 Push one of the LCD screen buttons until PLATFORM LEVEL SENSOR DEGREES appears.

- Result: The LCD screen should display the angle in degrees.

Test the Operating Envelope

21 Simultaneously push and then release the LCD screen buttons shown to activate status mode.



22 Push one of the LCD screen buttons shown until BOOM ANGLE is displayed.



23 Raise the boom and observe the LCD screen.

- Result: The LCD screen should display:
 - < 10
 - >= 10
 - >= 53
 - > 68

24 Push one of the LCD screen buttons shown until BOOM LENGTH is displayed.

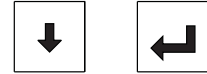

25 Extend the boom and observe the LCD screen.

- Result: The LCD screen should display:
 - at 0
 - > 0
 - > 75
 - = 100
 - > 100

26 Retract the boom.

At the Platform Controls**Test Emergency Stop**

27 Turn the key switch to platform control.

28 Push in the platform red Emergency Stop button to the off position.

- Result: The engine should turn off and no functions should operate.

29 Pull out the red Emergency Stop button and restart the engine.

Test the Hydraulic Oil Return Filter

30 Press the engine idle speed select button until the indicator light next to high idle (rabbit symbol) is on.

31 Locate and check the hydraulic filter condition indicator.

- Result: The indicator should be in the green area.

32 Press the engine idle speed select button until the indicator light next to foot switch activated high idle (rabbit and foot switch symbol) is on.

FUNCTION TESTS

Test the Horn

33 Push the horn button.

- ⦿ Result: The horn should sound.

Test the Tilt Sensor Alarm

34 Push a button, such as the engine RPM button or the fuel select button.

- ⦿ Result: The alarm should sound at the platform controls.

Test the Foot Switch

35 Push in the platform red Emergency Stop button to the off position.

36 Pull out the red Emergency Stop button to the on position but do not start the engine.

37 Press down the foot switch and attempt to start the engine by pushing the engine start button.

- ⦿ Result: The engine should not start.

38 Do not press down the foot switch and restart the engine.

39 Do not press down the foot switch and test each machine function.

- ⦿ Result: No machine functions should operate.

Test Machine Functions

40 Press down the foot switch.

41 Activate each machine function control handle, toggle switch or button.

- ⦿ Result: All functions should operate through a full cycle.

Test the Steering

42 Push the steer mode select button for square-end (blue arrow) steer.

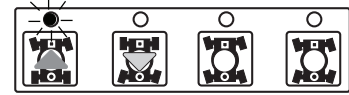

43 Press down the foot switch.

44 Slowly move the drive/steer control handle in the direction indicated by the blue triangle on the control panel OR press the thumb rocker switch in the direction indicated by the blue triangle.

- ⦿ Result: The square-end wheels should turn in the direction that the blue triangles point on the drive chassis.

45 Push the steer mode select button for circle-end (yellow arrow) steer.

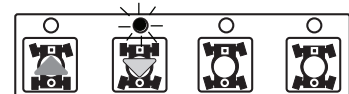

46 Press down the foot switch.

47 Slowly move the drive/steer control handle in the direction indicated by the yellow triangle on the control panel OR press the thumb rocker switch in the direction indicated by the yellow triangle.

- ⦿ Result: The circle-end wheels should turn in the direction that the yellow triangles point on the drive chassis.

48 Push the steer mode select button for crab steer.

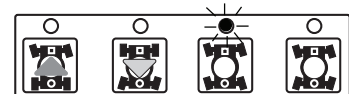

49 Press down the foot switch.

50 Slowly move the drive/steer control handle in the direction indicated by the blue triangle on the control panel OR press the thumb rocker switch in the direction indicated by the blue triangle.

- ⦿ Result: All wheels should turn in the direction that the blue triangles point on the drive chassis.

FUNCTION TESTS

- 51 Push the steer mode select button for coordinated steer.

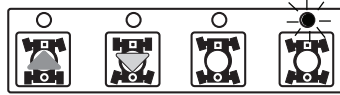

- 52 Press down the foot switch.
- 53 Slowly move the drive/steer control handle in the direction indicated by the blue triangle on the control panel OR press the thumb rocker switch in the direction indicated by the blue triangle.
- Result: The square-end wheels should turn in the direction that the blue triangles point on the drive chassis. The circle-end wheels should turn in the direction that the yellow triangles point on the drive chassis.

Test Drive and Braking

- 54 Press down the foot switch.
- 55 Slowly move the drive/steer control handle in the direction indicated by the blue arrow on the control panel until the machine begins to move, then return the handle to the center position.
- Result: The machine should move in the direction that the blue arrow points on the drive chassis, then come to an abrupt stop.
- 56 Slowly move the drive/steer control handle in the direction indicated by the yellow arrow on the control panel until the machine begins to move, then return the handle to the center position.
- Result: The machine should move in the direction that the yellow arrow points on the drive chassis, then come to an abrupt stop.

Note: The brakes must be able to hold the machine on any slope it is able to climb.

Test the Drive Enable System

- 57 Press down the foot switch and lower the boom to the stowed position.
- 58 Rotate the turntable until the boom moves past one of the circle-end tires.

- Result: The drive enable indicator light should come on while the boom is anywhere in the range shown.

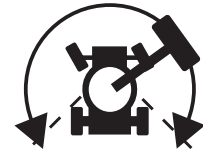

- 59 Move the drive/steer control handle off center.
- Result: No drive function should operate.
- 60 Push the drive enable button and slowly move the drive/steer control handle off center.
- Result: The drive function should operate.

Note: When the drive enable system is in use, the machine may drive in the opposite direction that the drive and steer control handle is moved.

Use the color-coded direction arrows on the platform controls and the drive chassis to identify the direction of travel.

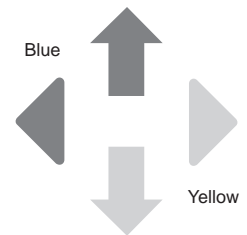

If the drive/steer control handle is not moved within two seconds of pushing the drive enable button, the drive function will not operate.

FUNCTION TESTS

Test Limited Drive Speed

61 Press down the foot switch.

62 Raise the boom to 10° above horizontal.

63 Slowly move the drive control handle to the full drive position.

- ⦿ Result: The maximum achievable drive speed with the boom raised should not exceed 1 foot / 30 cm per second.

Note: The machine will travel 40 feet / 12.2 m in 40 seconds.

64 Lower the boom to the stowed position.

65 Extend the boom 4 feet / 1.2 m.

66 Slowly move the drive control handle to the full drive position.

- ⦿ Result: The maximum achievable drive speed with the boom extended should not exceed 1 foot / 30 cm per second.

Note: The machine will travel 40 feet / 12.2 m in 40 seconds.

If the drive speed with the boom raised or extended exceeds 1 foot / 30 cm per second, immediately tag and remove the machine from service.

67 Raise the boom to horizontal. Extend the boom as far as it will go.

68 Slowly move the drive control handle to the full drive position.

- ⦿ Result: The maximum achievable drive speed with the boom fully extended should not exceed 0.6 feet / 18 cm per second.

Note: The machine will travel 40 feet / 12.2 meters in 70 seconds.

Test Auxiliary Controls

69 Shut off the engine.

70 Pull out the red Emergency Stop button to the on position.

71 Press down the foot switch.

72 Simultaneously press and hold the auxiliary power button and activate each function control handle, toggle switch or button.

Note: To conserve battery power, test each function through a partial cycle.

- ⦿ Result: All boom and steer functions should operate.

Workplace Inspection



Do Not Operate Unless:

You learn and practice the principles of safe machine operation contained in this operator's manual.

- 1 Avoid hazardous situations.
- 2 Always perform a pre-operation inspection.
- 3 Always perform function tests prior to use.

4 Inspect the workplace.

Know and understand the above principles before going on to the next section.

- 5 Only use the machine as it was intended.

Workplace Inspection

Be aware of and avoid the following hazardous situations:

- drop-offs or holes
- bumps, floor obstructions or debris
- sloped surfaces
- unstable or slippery surfaces
- overhead obstructions and high voltage conductors
- hazardous locations
- inadequate surface support to withstand all load forces imposed by the machine
- wind and weather conditions
- the presence of unauthorized personnel
- other possible unsafe conditions

Fundamentals

The workplace inspection helps the operator determine if the workplace is suitable for safe machine operation. It should be performed by the operator prior to moving the machine to the workplace.

It is the operator's responsibility to read and remember the workplace hazards, then watch for and avoid them while moving, setting up and operating the machine.

Operating Instructions



Do Not Operate Unless:

- You learn and practice the principles of safe machine operation contained in this operator's manual.
 - 1 Avoid hazardous situations.
 - 2 Always perform a pre-operation inspection.
 - 3 Always perform function tests prior to use.
 - 4 Inspect the work place.
 - 5 Only use the machine as it was intended.**

Fundamentals

The Operating Instructions section provides instructions for each aspect of machine operation. It is the operator's responsibility to follow all the safety rules and instructions in the operator's, safety and responsibilities manuals.

Using the machine for anything other than lifting personnel, along with their tools and materials, to an aerial work site is unsafe and dangerous.

Only trained and authorized personnel should be permitted to operate a machine. If more than one operator is expected to use a machine at different times in the same work shift, they must all be qualified operators and are all expected to follow all safety rules and instructions in the operator's, safety and responsibilities manuals. That means every new operator should perform a pre-operation inspection, function tests, and a work place inspection before using the machine.

OPERATING INSTRUCTIONS

Starting the Engine

- 1 At the ground controls, turn the key switch to the desired position.
- 2 Be sure both ground and platform control red Emergency Stop buttons are pulled out to the on position.

Diesel models

- 3 Press the engine start button.

Note: In cold conditions, 50°F / 10°C and below, push and hold the glow plug button for 10 to 20 seconds before starting the engine.



Gasoline/LPG models

- 3 Choose fuel by pressing the fuel select button.
- 4 Push the engine start button.

Note: In cold conditions, 20°F / -6°C and below, the machine should be started on gasoline and warmed for 2 minutes, then switched to LPG. Warm engines can be started on LPG.

All models

If the engine fails to start or dies, the restart delay will disable the start switch for 3 seconds.

If the engine fails to start after 15 seconds of cranking, determine the cause and repair any malfunction. Wait 60 seconds before trying to start again.

In cold conditions, 20°F / -6°C and below, warm the engine for 5 minutes before operating to prevent hydraulic system damage.

In extreme cold conditions, 0°F / -18°C and below, machines should be equipped with optional cold start kits. Attempting to start the engine when temperatures are below 0°F / -18°C may require the use of a booster battery.

Emergency Stop

Push in either the ground or platform red Emergency Stop button to the off position to stop all functions and turn the engine off.

Repair any function that operates when the red Emergency Stop button is pushed in to the off position.

Selecting and operating the ground controls will override the platform red Emergency Stop button.

Auxiliary Controls



Use auxiliary power if the primary power source (engine) fails.

- 1 Turn the key switch to ground or platform control.
- 2 Pull out the red Emergency Stop button to the on position.
- 3 Press down the foot switch when operating the auxiliary controls from the platform.
- 4 Simultaneously hold the auxiliary power button and activate the desired function.

Operation from Ground

- 1 Turn the key switch to ground control.
- 2 Pull out the red Emergency Stop button to the on position.
- 3 Gasoline/LPG models: Choose fuel by pressing the fuel select button.
- 4 Start the engine.

OPERATING INSTRUCTIONS

To Position Platform

- 1 Push and hold a function enable/speed select button.
- 2 Push the appropriate function button according to the markings on the control panel.



Drive and steer functions are not available from the ground controls.

Operation from Platform

- 1 Turn the key switch to platform control.
- 2 Pull out both ground and platform red Emergency Stop buttons to the on position.
- 3 Gasoline/LPG models: Choose fuel by pressing the fuel select button.
- 4 Start the engine. Do not press down the foot switch when starting the engine.

To Position Platform

- 1 Press down the foot switch.
- 2 Slowly move the appropriate function control handle or toggle switch or press the appropriate button according to the markings on the control panel.

To Steer

- 1 Press down the foot switch.
- 2 Select the steer mode by pressing a steer mode button. The indicator light next to the current steer mode will be on.

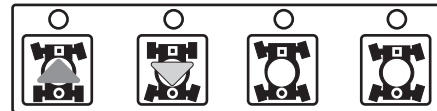

- 3 Slowly move the drive/steer control handle in the direction of the blue or yellow triangle OR press the thumb rocker switch located on top of the drive control handle.



Use the color-coded direction triangles on the platform controls and the drive chassis to identify the direction the wheels will turn.

To Drive

- 1 Press down the foot switch.
- 2 Increase speed: Slowly move the drive/steer control in the blue or yellow arrow direction.



Decrease speed: Slowly move the drive/steer control handle toward center.

Stop: Return the drive/steer control handle to center or release the foot switch.

Use the color-coded direction arrows on the platform controls and the drive chassis to identify the direction the machine will travel.

Machine travel speed is restricted when the boom is raised or extended.

OPERATING INSTRUCTIONS

Driving on a slope

Determine the uphill, downhill and side slope ratings for the machine and determine the slope grade.



Maximum slope rating, counterweight uphill (gradeability): 40% (22°)



Maximum slope rating, counterweight downhill: 40% (22°)



Maximum side slope rating: 25% (14°)

Note: Slope rating is subject to ground conditions and adequate traction. The term gradeability applies to the counterweight uphill configuration only.

Be sure the boom is below horizontal and the platform is between the non-steer wheels.

To determine the slope grade:

Measure the slope with a digital inclinometer OR use the following procedure.

You will need:

- carpenter's level
- straight piece of wood, at least 3 feet / 1 m long
- tape measure

Lay the piece of wood on the slope.

At the downhill end, lay the level on the top edge of the piece of wood and lift the end until the piece of wood is level.

While holding the piece of wood level, measure the distance from the bottom of the piece of wood to the ground.

Divide the tape measure distance (rise) by the length of the piece of wood (run) and multiply by 100.

Example:

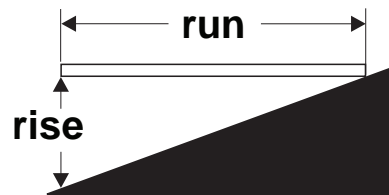

Piece of wood = 144 inches (3.6 m)

Run = 144 inches (3.6 m)

Rise = 12 inches (0.3 m)

$12 \text{ in} \div 144 \text{ in} = 0.083 \times 100 = 8.3\% \text{ grade}$

$0.3 \text{ m} \div 3.6 \text{ m} = 0.083 \times 100 = 8.3\% \text{ grade}$

If the slope exceeds the maximum uphill, downhill or side slope rating, then the machine must be winched or transported up or down the slope. See Transport and Lifting Instructions section.

OPERATING INSTRUCTIONS

Drive Enable

Light on indicates that the boom has moved past either circle-end wheel and drive function is turned off.



To drive, push the drive enable button and slowly move the drive/steer control handle off center.

If the drive/steer control handle is not moved within two seconds of pushing the drive enable button, the drive function will not operate. Release and push the drive enable button again.

Be aware that the machine may move in the opposite direction that the drive and steer controls are moved.

Always use the color-coded direction arrows on the platform controls and the drive chassis to identify the direction the machine will travel.

Engine Idle Select (rpm)

Select the engine idle (rpm) by pressing the select button. The indicator light next to the current setting will be on.



- Rabbit and foot switch symbol: foot switch activated high idle
- Turtle symbol: low idle
- Rabbit symbol: high idle

Check Engine Light



Light on and engine stopped: Tag the machine and remove from service.

Light on and engine still running: Contact service personnel within 24 hours.

Operating Envelope Indicator Lights

The operating envelope indicator lights will come on to notify the operator that a function has been interrupted (in some cases) and/or an action is required by the operator.

Raise Boom indicator light flashing: To continue extending the boom, raise the boom until the indicator light is off.



Retract Boom indicator light flashing: To continue lowering the boom, retract the boom until the indicator light is off.



Machine Not Level indicator light flashing: The tilt alarm will be sounding when this light is flashing. Move the machine to a firm level surface.



Platform Not Level indicator light flashing: The tilt alarm will be sounding when this light is flashing. The Platform Level toggle switch will only work in the direction that will level the platform. Level the platform until the indicator light is off.



OPERATING INSTRUCTIONS

Regulated Generator (if equipped)

To operate the generator, press the generator button. The indicator light will come on and the engine will continue to run.

Plug power tools into the power to platform GFCI outlet.

To turn off the generator, push the generator button. The indicator light will turn off.

Non-regulated Generator (if equipped)

To operate the generator, press the generator button. The indicator light will come on and the engine rpm will automatically be in turtle symbol mode.

The engine will continue to run the drive functions and the platform functions will operate.

If the rabbit symbol or the rabbit and foot switch symbol are selected, the generator will shut off and the indicator light will go off.

Plug power tools into the power to platform GFCI outlet.

To turn off the generator, push the generator button. The indicator light will turn off.

Platform Overload Indicator Light (if equipped)



Light flashing indicates the platform is overloaded. The engine will stop and no functions will operate.

Remove weight from the platform until the light goes off and then restart the engine.

Fall Protection

Personal fall protection equipment (PFPE) is required when operating this machine.

All PFPE must comply with applicable governmental regulations, and must be inspected and used in accordance with the PFPE manufacturer's instructions.

After Each Use

- 1 Select a safe parking location—firm level surface, clear of obstruction and traffic.
- 2 Retract and lower the boom to the stowed position.
- 3 Rotate the turntable so that the boom is between the circle-end wheels.
- 4 Turn the key switch to the off position and remove the key to secure from unauthorized use.
- 5 Chock the wheels.

Transport and Lifting Instructions



Transport Instructions Observe and Obey:

- ☑ Genie Industries provides this securement information as a recommendation. Drivers are solely responsible for making sure machines are properly secured and the correct trailer is selected pursuant to US Department of Transportation regulations, other localized regulations, and their company policy.
- ☑ Genie customers needing to containerize any lift or Genie product should source a qualified freight forwarder with expertise in preparing, loading and securing construction and lifting equipment for international shipment.
- ☑ Only qualified aerial lift operators should move the machine on or off the truck.
- ☑ Transport vehicle must be parked on a level surface.
- ☑ Transport vehicle must be secured to prevent rolling while machine is being loaded.
- ☑ Be sure vehicle capacity, loading surfaces and straps or lines are sufficient to withstand machine weight. See the serial plate for the machine weight.
- ☑ Be sure the turntable is secured with the turntable rotation lock before transporting. Be sure to unlock the turntable for operation.
- ☑ Do not drive the machine on a slope that exceeds the slope or side slope rating. See Driving on a Slope in the Operating Instructions section.
- ☑ If the slope of the transport vehicle bed exceeds the uphill or downhill maximum slope rating, the machine must be loaded and unloaded using a winch as described.

Free-wheel Configuration for Winching

Chock the wheels to prevent the machine from rolling.

Release the wheel brakes by turning over all four torque hub disconnect caps.

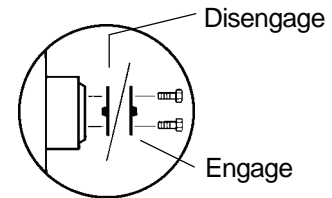

Be sure the winch line is properly secured to the drive chassis tie points and the path is clear of all obstructions.

Reverse the procedures described to re-engage the brakes.

TRANSPORT AND LIFTING INSTRUCTIONS

Securing to Truck or Trailer for Transit

Always use the turntable rotation lock pin each time the machine is transported.

Turn the key switch to the off position and remove the key before transporting.

Inspect the entire machine for loose or unsecured items.

Securing the Chassis

Use chains of ample load capacity.

Use a minimum of 5 chains.

Adjust the rigging to prevent damage to the chains.

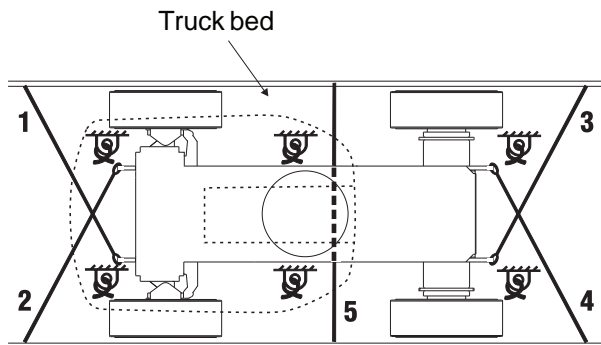

Securing the Platform - S-100 and S-120

Lower the boom to the stowed position.

Raise the platform as far as it will go (see below).

Run a strap through the platform support between the plates next to the rotator.

Anchor the strap to each corner of the truck bed.

The platform will hang over the end of the truck.

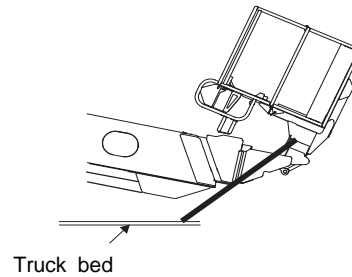

Securing the Platform - S-105 and S-125

Lower the boom and rotate the jib under the boom arm (see below).

Run a strap through the platform support between the plates next to the rotator.

Anchor the strap to each corner of the truck bed.

The platform will hang over the end of the truck.

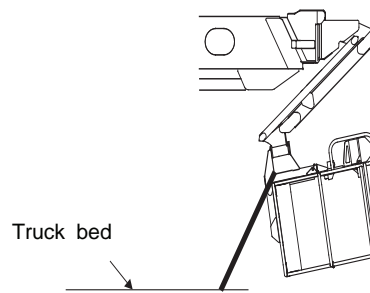

TRANSPORT AND LIFTING INSTRUCTIONS



Observe and Obey:

- ☑ Only qualified riggers should rig and lift the machine.
- ☑ Be sure the crane capacity, loading surfaces and straps or lines are sufficient to withstand the machine weight. See the serial plate for the machine weight.

Lifting Instructions

Fully lower and retract the boom. Remove all loose items on the machine.

Use the turntable rotation lock to secure the turntable.

Determine the center of gravity of your machine using the table and the picture on this page.

Attach the rigging only to the designated lifting points on the machine. There are two lifting points on the chassis and two on the turntable.

Adjust the rigging to prevent damage to the machine and to keep the machine level.

Use a spreader bar to keep the rigging from damaging the machine.

Center of Gravity Location

	X Axis	Y Axis
S-100	6.81 ft 2.08 m	4.26 ft 1.30 m
S-105	6.62 ft 2.02 m	4.95 ft 1.51 m
S-120	6.55 ft 2.0 m	4.40 ft 1.34 m
S-125	6.32 ft 1.93 m	5.10 ft 1.55 m

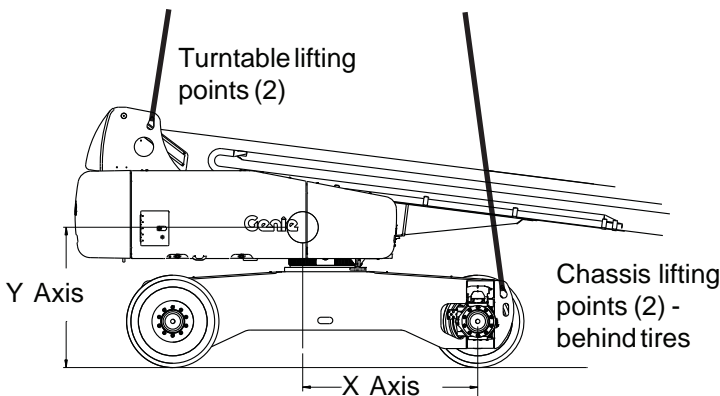

Decals

Inspection for Decals with Words

Determine whether the decals on your machine have words or symbols. Use the appropriate inspection to verify that all decals are legible and in place.

Part No.	Description	Quantity
25994	Caution - Component Damage Hazard	1
27204	Arrow - Blue	1
27205	Arrow - Yellow	1
27206	Triangle - Blue	4
27207	Triangle - Yellow	4
27564	Danger - Electrocutation Hazard	4
28159	Label - Diesel	1
28161	Warning - Crushing Hazard	6
28164	Notice - Hazardous Materials	1
28165	Notice - Foot Switch	1
28171	Label - No Smoking	1
28174	Label - Power to Platform, 230V	2
28175	Caution - Compartment Access	1
28176	Notice - Missing Manuals	1
28177	Warning - Platform Rotate	2
28181	Warning - No Step or Ride	1
28235	Label - Power to Platform, 115V	2
28236	Warning - Failure To Read . . .	1
30080	Notice - Max. Capacity, 500 lbs / 227 kg	1
33952	Danger - Tip-over Hazard	1
40434	Label - Lanyard Anchorage Point	3
43594	Notice - Max. Capacity, 750 lbs / 340 kg,	1
44981	Label - Air Line to Platform (option)	2
44986	Notice - Max. Manual Force, 90 lbs / 400 N	1
61227	Ground Control Panel	1

Part No.	Description	Quantity
65182	Platform Control Panel	1
65264	Cosmetic - Genie S-125	1
65265	Cosmetic - S-125	1
65266	Cosmetic - 4x4	1
65267	Cosmetic - Genie S-120	1
65268	Cosmetic - S-120	1
65273	Notice - Tire Specifications, S-120/S-125	4
65278	Caution - No Step	4
65428	Danger - Tip-over Hazard, Tires	4
72053	Label - 30 amp Circuit Breaker (option)	1
72119	Label - Range of Motion, S-120/S-125	1
72130	Warning - Bodily Injury Hazard	4
72131	Label - Cylinder Cover	4
72147	Cosmetic - Genie S-100	1
72148	Cosmetic - Genie S-105	1
72149	Cosmetic - S-100	1
72150	Cosmetic - S-105	1
72151	Notice - Tire Specifications, S-100/S-105	4
72152	Label - Range of Motion, S-100/S-105	1
72168	Notice - Starter Battery	1
72169	Notice - Controls Battery	1
72968	Label - 25 amp Circuit Breaker	1
82366	Label - Chevron Rykon	1

This inspection continues on the next page.

DECALS

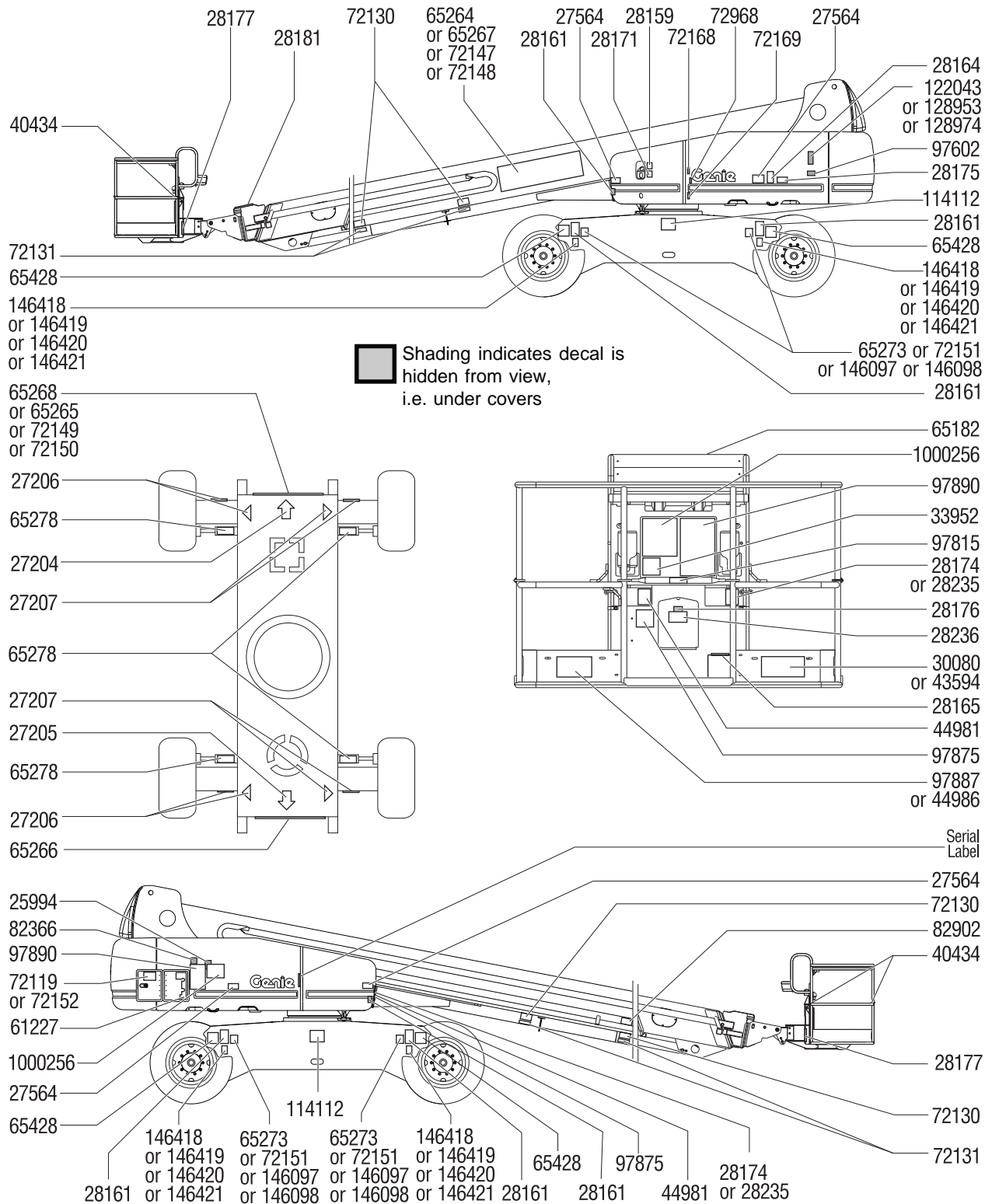

■ Shading indicates decal is hidden from view, i.e. under covers



DECALS

Inspection for Decals with Words

Determine whether the decals on your machine have words or symbols. Use the appropriate inspection to verify that all decals are legible and in place.

This inspection is a continuation from the previous page.

Part No.	Description	Quantity
82902	Danger - Tip over hazard, S-120/S-125	1
97602	Warning - Explosion Hazard	1
97815	Label - Lower Midrail	1
97875	Warning - Weld Line to Platform (option)	2
97887	Notice - Max. Side Force, 150 lbs / 667 N	1
97890	Danger - General Safety	2
114112	Label - Transport Diagram	2
122043	Notice - Engine Specs, Cummins	1
128953	Notice - Engine Specs, Deutz	1
128974	Notice - Engine Specs, Perkins	1
146097	Danger - Tire Specifications, S-100, S-105	4
146098	Danger - Tire Specifications, S-120, S-125	4
146418	Label - Wheel Load, S-100	4
146419	Label - Wheel Load, S-105	4
146420	Label - Wheel Load, S-120	4
146421	Label - Wheel Load, S-125	4
1000256	Notice - Operating Instructions	2

DECALS

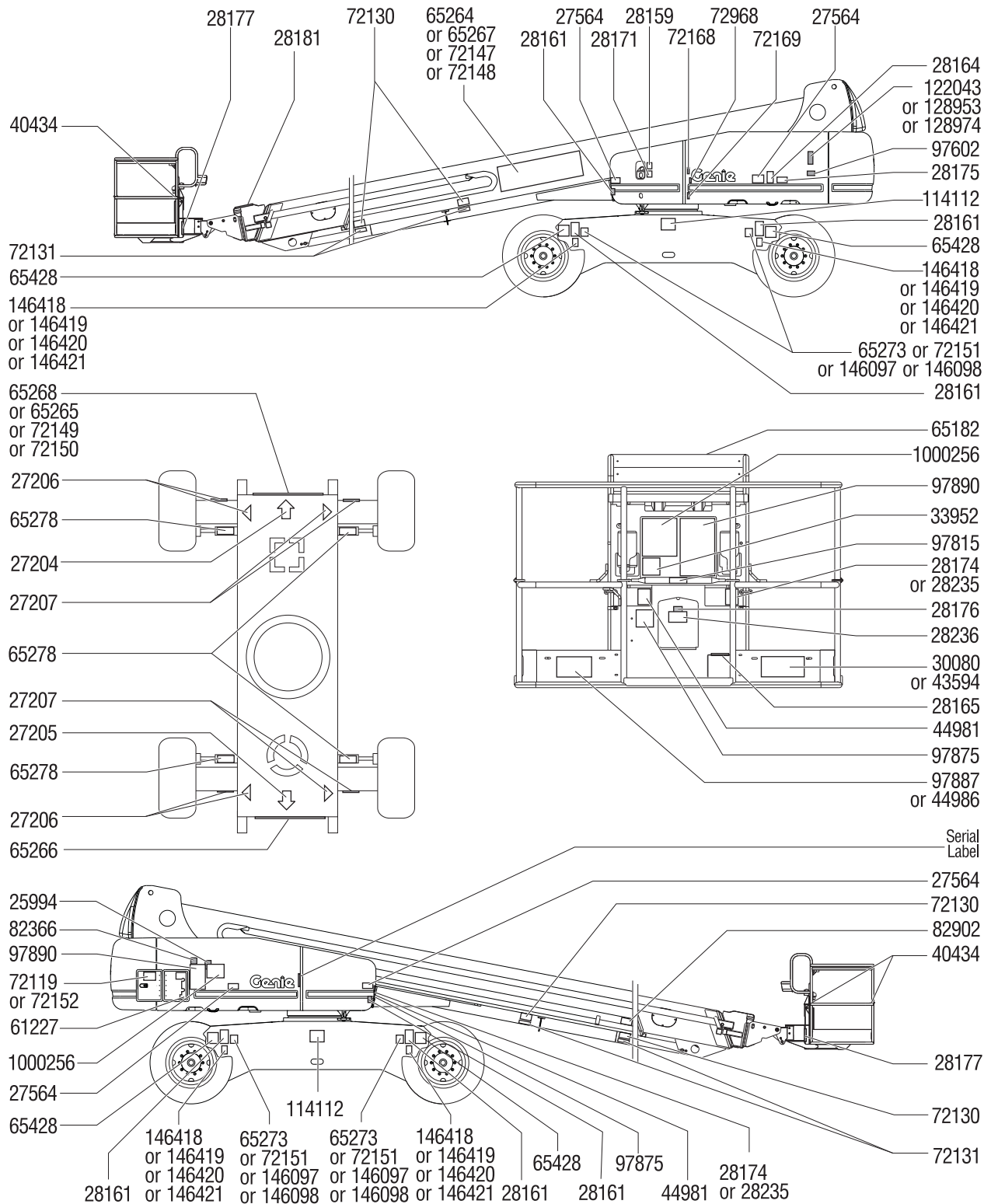

DECALS

Inspection for Decals with Symbols

Determine whether the decals on your machine have words or symbols. Use the appropriate inspection to verify that all decals are legible and in place.

Part No.	Description	Quantity
27204	Arrow - Blue	1
27205	Arrow - Yellow	1
27206	Triangle - Blue	4
27207	Triangle - Yellow	4
28159	Label - Diesel	1
28171	Label - No Smoking	1
28174	Label - Power to Platform, 230V	2
28235	Label - Power to Platform, 115V	2
40434	Label - Lanyard Anchorage Point	3
44981	Label - Air Line to Platform (option)	2
61227	Ground Control Panel	1
65182	Platform Control Panel	1
65264	Cosmetic - Genie S-125	1
65265	Cosmetic - S-125	1
65266	Cosmetic - 4x4	1
65267	Cosmetic - Genie S-120	1
65268	Cosmetic - S-120	1
72119	Label - Range of Motion, S-120/S-125	1
72147	Cosmetic - Genie S-100	1
72148	Cosmetic - Genie S-105	1
72149	Cosmetic - S-100	1
72150	Cosmetic - S-105	1
72152	Label - Range of Motion, S-100/S-105	1
82240	Label, Noise Level (CE only)	1

Part No.	Description	Quantity
82472	Warning - Crushing Hazard	6
82473	Caution - Compartment Access	1
82487	Label - Read the Manual	2
82544	Danger - Electrocutation Hazard	4
82545	Danger - Maximum Capacity, 227 kg, S-105/S-125	1
82547	Danger - Maximum Capacity, 340 kg, S-100/S-120	1
82548	Warning - Platform Rotate	2
82577	Label - Platform Overload Patch	1
82602	Danger - Max Manual Force, 667N	1
82603	Label - Drive Enable Patch	1
82604	Danger - Max Manual Force, 400N	1
82607	Caution - No Step	4
82671	Label - Weld Line to Platform (option)	2
82924	Caution - Component Damage Hazard	1
97815	Label - Lower Mid-rail	1
114112	Label - Transport Diagram	2
146418	Label - Wheel Load, S-100	4
146419	Label - Wheel Load, S-105	4
146420	Label - Wheel Load, S-120	4
146421	Label - Wheel Load, S-125	4

DECALS

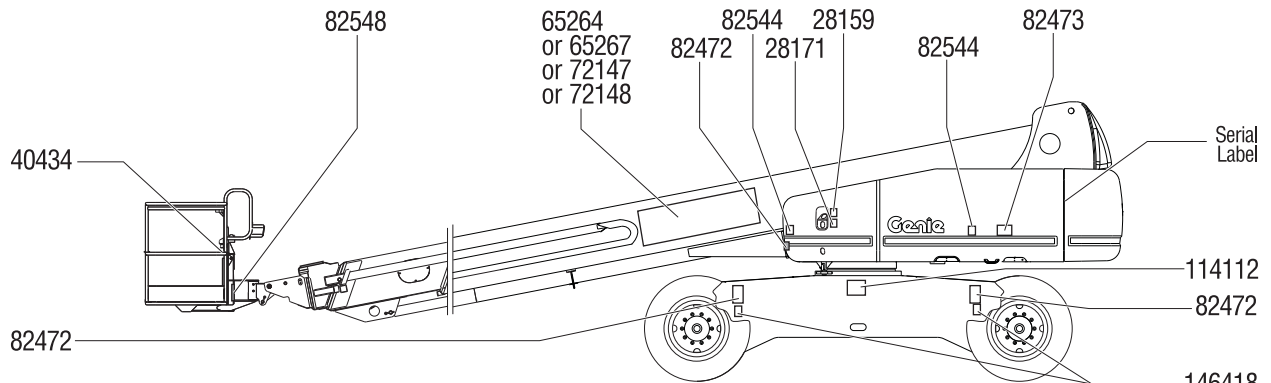

65268
or 65265
or 72149
or 72150

■ Shading indicates decal is hidden from view, i.e. under covers

146418
or 146419
or 146420
or 146421

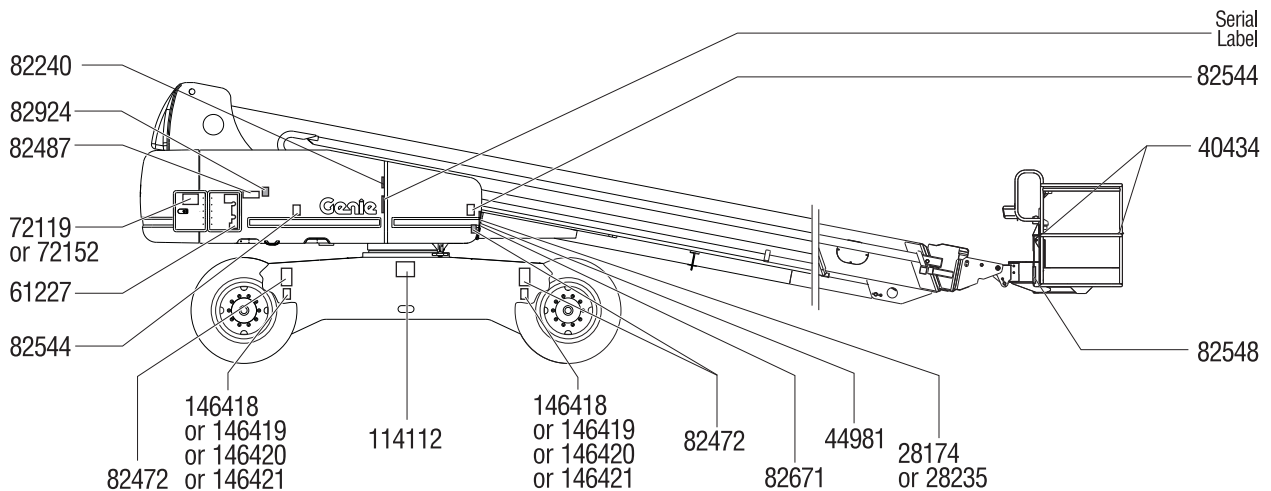
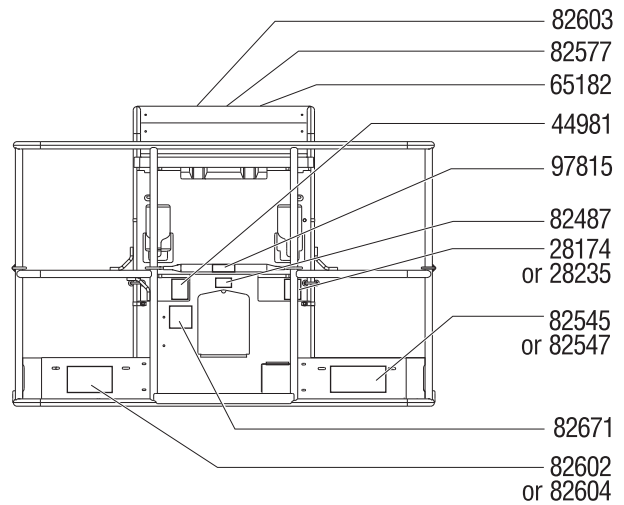
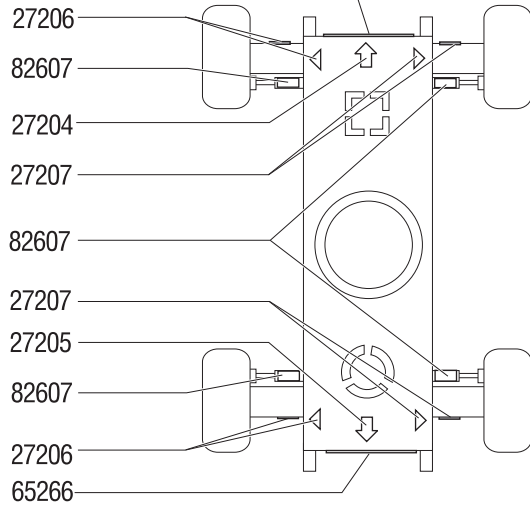

Specifications

S-100		
Height, working maximum	106 ft	32.5 m
Height, platform maximum	100 ft	30.5 m
Height, stowed maximum	10 ft 1 in	3.1 m
Horizontal reach maximum	75 ft	22.9 m
Width, axles retracted	8 ft 2 in	2.5 m
Width, axles extended	11 ft	3.35 m
Length, stowed	42 ft 8 in	13 m
Maximum load capacity	750 lbs	340 kg
Maximum wind speed	28 mph	12.5 m/s
Wheelbase	12 ft	3.7 m
Turning radius, inside, axles extended	9 ft	2.74 m
Turning radius, outside, axles extended	19 ft 10 in	6.05 m
Turning radius, inside, axles retracted	13 ft 7 in	4.14 m
Turning radius, outside, axles retracted	21 ft 7 in	6.58 m
Turntable rotation (degrees)	360 continuous	
Turntable tailswing, axles retracted	5 ft 6 in	1.68 m
Turntable tailswing, axles extended	4 ft	1.22 m
Controls	12V DC proportional	
Platform dimensions, length x width	96 x 36 in 2.4 m x 91 cm	
Platform leveling	self-leveling	
Platform rotation	160°	
AC outlet in platform	standard	
Hydraulic pressure, maximum (drive functions)	4250 psi	293 bar
System voltage	12V	
Vibration value does not exceed 2.5 m/s ²		

Tire size, foam-filled tires	385/65 D22.5 16 ply	
Tire size, solid rubber tires	385/65 D24	
Ground clearance	14 in	35.6 cm
Fuel tank capacity	40 gallons	151 liters
Weight	See Serial Label (Machine weights vary with option configurations)	
Drive speeds		
Drive speed, stowed	3.0 mph 40 ft/9.1 sec	4.4 km/h 12.2 m/9.1 sec
Drive speed, raised or extended	0.7 mph 40 ft/40 sec	1.1 km/h 12.2 m/40 sec
Drive speed, fully extended	0.4 mph 40 ft/70 sec	0.6 km/h 12.2 m/70 sec

Maximum slope rating, stowed position

Counterweight uphill	40% (22°)
Counterweight downhill	40% (22°)
Side slope	25% (14°)

Note: Slope rating is subject to ground conditions and adequate traction.

Floor loading information

Tire load, maximum	18,650 lbs	8460 kg
Tire contact pressure	105 psi	7.4 kg/cm ² 724 kPa
Occupied floor pressure, axles extended	240 psf	1172 kg/m ² 11.5 kPa
Occupied floor pressure, axles retracted	318 psf	1552 kg/m ² 15.2 kPa

Note: Floor loading information is approximate and does not incorporate different option configurations. It should be used only with adequate safety factors.

Continuous improvement of our products is a Genie policy. Product specifications are subject to change without notice or obligation.



SPECIFICATIONS

S-105

Height, working maximum	111 ft	34 m
Height, platform maximum	105 ft	32 m
Height, stowed maximum	10 ft 1 in	3.1 m
Horizontal reach maximum	81 ft	24.7 m
Width, axles retracted	8 ft 2 in	2.5 m
Width, axles extended	11 ft	3.35 m
Length, stowed	46 ft	14 m
Maximum load capacity	500 lbs	227 kg
Maximum wind speed	28 mph	12.5 m/s
Wheelbase	12 ft	3.7 m
Turning radius, inside, axles extended	9 ft	2.74 m
Turning radius, outside, axles extended	19 ft 10 in	6.05
Turning radius, inside, axles retracted	13 ft 7 in	4.14 m
Turning radius, outside, axles retracted	21 ft 7 in	6.58 m
Turntable rotation (degrees)	360 continuous	
Turntable tailswing, axles retracted	5 ft 6 in	1.68 m
Turntable tailswing, axles extended	4 ft	1.22 m
Controls	12V DC proportional	
Platform dimensions, length x width	96 x 36 in 2.4 m x 91 cm	
Platform leveling	self-leveling	
Platform rotation	160°	
AC outlet in platform	standard	
Hydraulic pressure, maximum (drive functions)	4250 psi	293 bar
System voltage	12V	
Vibration value does not exceed 2.5 m/s ²		

Tire size, foam-filled tires	385/65 D22.5 16 ply	
Tire size, solid rubber tires	385/65 D24	
Ground clearance	14 in	35.6 cm
Fuel tank capacity	40 gallons	151 liters
Weight	See Serial Label (Machine weights vary with option configurations)	

Drive speeds

Drive speed, stowed	3.0 mph 40 ft/9.1 sec	4.4 km/h 12.2 m/9.1 sec
Drive speed, raised or extended	0.7 mph 40 ft/40 sec	1.1 km/h 12.2 m/40 sec
Drive speed, fully extended	0.4 mph 40 ft/70 sec	0.6 km/h 12.2 m/70 sec

Maximum slope rating, stowed position

Counterweight uphill	40% (22°)
Counterweight downhill	40% (22°)
Side slope	25% (14°)

Note: Slope rating is subject to ground conditions and adequate traction.

Floor loading information

Tire load, maximum	21,200 lbs	9617 kg
Tire contact pressure	105 psi	7.4 kg/cm ² 724 kPa
Occupied floor pressure, axles extended	240 psf	1172 kg/m ² 11.5 kPa
Occupied floor pressure, axles retracted	318 psf	1552 kg/m ² 15.2 kPa

Note: Floor loading information is approximate and does not incorporate different option configurations. It should be used only with adequate safety factors.

Continuous improvement of our products is a Genie policy. Product specifications are subject to change without notice or obligation.



SPECIFICATIONS

S-120		
Height, working maximum	126 ft	38.6 m
Height, platform maximum	120 ft	36.6 m
Height, stowed maximum	10 ft 1 in	3.1 m
Horizontal reach maximum	75 ft	22.9 m
Width, axles retracted	8 ft 2 in	2.5 m
Width, axles extended	11 ft	3.35 m
Length, stowed	42 ft 8 in	13 m
Maximum load capacity	750 lb	340 kg
Maximum wind speed	28 mph	12.5 m/s
Wheelbase	12 ft	3.7 m
Turning radius, inside, axles extended	8 ft 6 in	2.6 m
Turning radius, outside, axles extended	18 ft 10 in	5.7 m
Turning radius, inside, axles retracted	13 ft 2 in	4.01 m
Turning radius, outside, axles retracted	22 ft 1 in	6.7 m
Turntable rotation (degrees)	360 continuous	
Turntable tailswing, axles retracted	5 ft 6 in	1.68 m
Turntable tailswing, axles extended	4 ft	1.22 m
Controls	12V DC proportional	
Platform dimensions, length x width	96 x 36 in 2.4 m x 91 cm	
Platform leveling	self-leveling	
Platform rotation	160°	
AC outlet in platform	standard	
Hydraulic pressure, maximum (drive functions)	4250 psi	293 bar
System voltage	12V	
Vibration value does not exceed 2.5 m/s ²		

Fuel tank capacity	40 gallons	151 liters
Tire size, foam-filled tires	445/65 D22.5 18 ply	
Tire size, solid rubber tires	445/65 D24	
Ground clearance	15 ³ / ₄ in	40 cm
Weight	See Serial Label (Machine weights vary with option configurations)	

Drive speeds

Drive speed, stowed	3.0 mph 40 ft/9.1 sec	4.4 km/h 12.2 m/9.1 sec
Drive speed, raised or extended	0.7 mph 40 ft/40 sec	1.1 km/h 12.2 m/40 sec
Drive speed, fully extended	0.4 mph 40 ft/70 sec	0.6 km/h 12.2 m/70 sec

Maximum slope rating, stowed position

Counterweight uphill	40% (22°)
Counterweight downhill	40% (22°)
Side slope	25% (14°)

Note: Slope rating is subject to ground conditions and adequate traction.

Floor loading information

Tire load, maximum	21,250 lbs	9639 kg
Tire contact pressure	105 psi	7.4 kg/cm ² 724 kPa
Occupied floor pressure, axles extended	266 psf	1299 kg/m ² 12.7 kPa
Occupied floor pressure, axles retracted	353 psf	1723 kg/m ² 16.9 kPa

Note: Floor loading information is approximate and does not incorporate different option configurations. It should be used only with adequate safety factors.

Continuous improvement of our products is a Genie policy. Product specifications are subject to change without notice or obligation.



SPECIFICATIONS

S-125

Height, working maximum	131 ft	40.1 m
Height, platform maximum	125 ft	38.1 m
Height, stowed maximum	10 ft 1 in	3.1 m
Horizontal reach maximum	81 ft	24.7 m
Width, axles retracted	8 ft 2 in	2.5 m
Width, axles extended	11 ft	3.35 m
Length, stowed	46 ft 9 in	14.2 m
Maximum load capacity	500 lb	227 kg
Maximum wind speed	28 mph	12.5 m/s
Wheelbase	12 ft	3.7 m
Turning radius, inside, axles extended	8 ft 6 in	2.6 m
Turning radius, outside, axles extended	18 ft 10 in	5.7 m
Turning radius, inside, axles retracted	13 ft 2 in	4.01 m
Turning radius, outside, axles retracted	22 ft 1 in	6.7 m
Turntable rotation (degrees)	360 continuous	
Turntable tailswing, axles retracted	5 ft 6 in	1.68 m
Turntable tailswing, axles extended	4 ft	1.22 m
Controls	12V DC proportional	
Platform dimensions, length x width	96 x 36 in 2.4 m x 91 cm	
Platform leveling	self-leveling	
Platform rotation	160°	
AC outlet in platform	standard	
Hydraulic pressure, maximum (drive functions)	4250 psi	293 bar
System voltage	12V	
Vibration value does not exceed 2.5 m/s ²		

Fuel tank capacity	40 gallons	151 liters
Tire size, foam-filled tires	445/65 D22.5 18 ply	
Tire size, solid rubber tires	445/65 D24	
Ground clearance	15 ³ / ₄ in	40 cm
Weight	See Serial Label (Machine weights vary with option configurations)	

Drive speeds

Drive speed, stowed	3.0 mph 40 ft/9.1 sec	4.4 km/h 12.2 m/9.1 sec
Drive speed, raised or extended	0.7 mph 40 ft/40 sec	1.1 km/h 12.2 m/40 sec
Drive speed, fully extended	0.4 mph 40 ft/70 sec	0.6 km/h 12.2 m/70 sec

Maximum slope rating, stowed position

Counterweight uphill	40% (22°)
Counterweight downhill	40% (22°)
Side slope	25% (14°)

Note: Slope rating is subject to ground conditions and adequate traction.

Floor loading information

Tire load, maximum	23,750 lbs	10,773 kg
Tire contact pressure	105 psi	7.4 kg/cm ² 724 kPa
Occupied floor pressure, axles extended	265 psf	1294 kg/m ² 12.7 kPa
Occupied floor pressure, axles retracted	353 psf	1723 kg/m ² 16.9 kPa

Note: Floor loading information is approximate and does not incorporate different option configurations. It should be used only with adequate safety factors.

Continuous improvement of our products is a Genie policy. Product specifications are subject to change without notice or obligation.



SPECIFICATIONS

Airbourne noise emissions

Sound pressure level at ground workstation	83 dBA
Sound pressure level at platform workstation	71 dBA
Guaranteed sound power level	105 dBA

SPECIFICATIONS

S-100 Range of Motion Chart

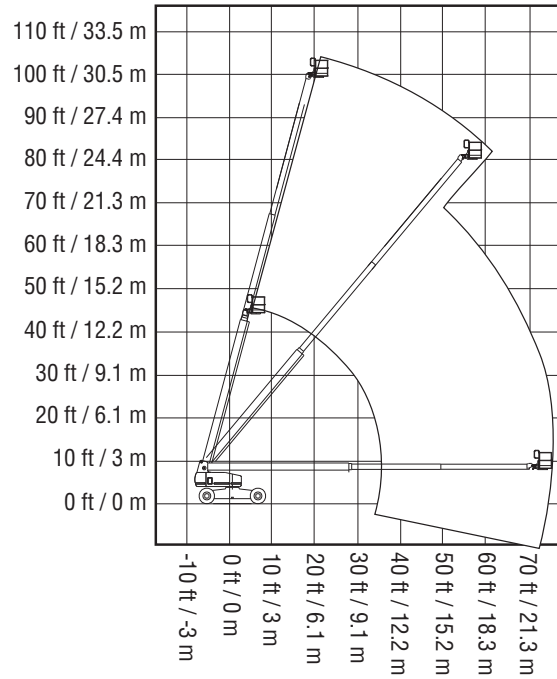

S-105 Range of Motion Chart

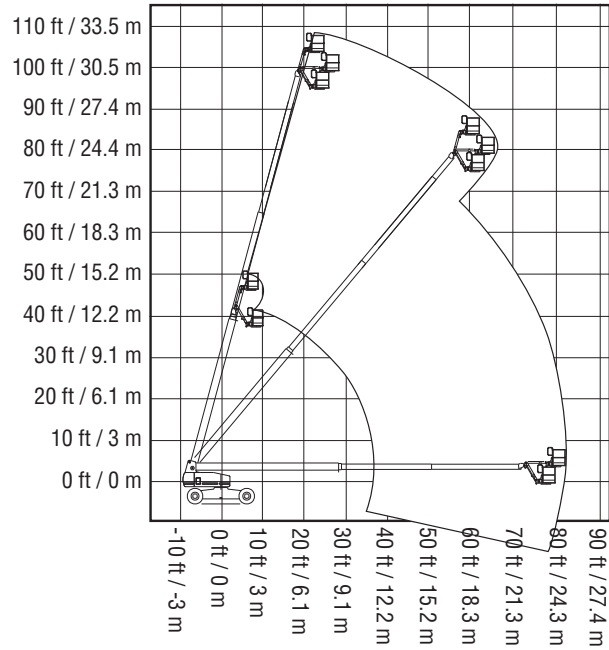

S-120 Range of Motion Chart

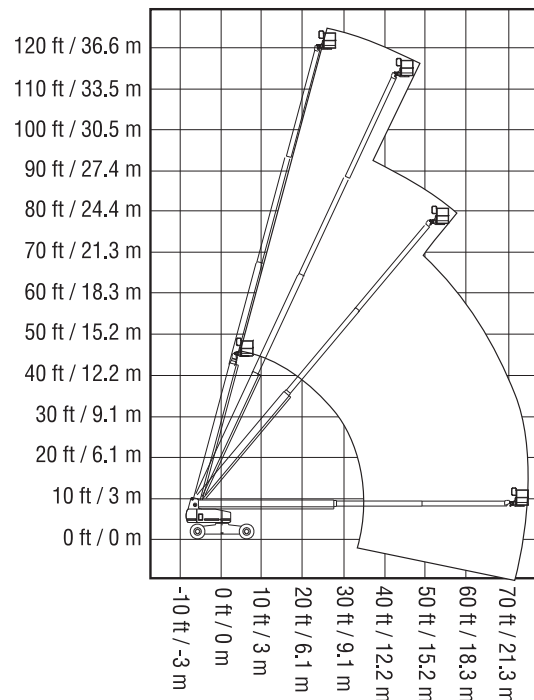

S-125 Range of Motion Chart

